



DISPENSERS



PUMPS



METERS



METERED NOZZLES



NOZZLES

DEF BLUE BOX PEDESTAL

FEATURES

- EASY TO INSTALL
- READY TO USE
- BUILT-IN LOCK

The PIUSI DEF Blue Box Pedestal is specifically designed for wall or tank installation, or can be mounted atop an optional pedestal. It is covered by a lockable metal container which protects the pump when not in use.

PERFORMANCE

UP TO

9 GPM

FLOW RATE

AC V. / Hz

120/60

VOLTAGE

POWER

± 1%

ACCURACY

20 MIN

DUTY CYCLE



DEF BLUE BOX PEDESTAL (FULLY ASSEMBLED)



PACKAGING (BLUE BOX)

PART #	WEIGHT		PACKAGING		
	KG	LBS	MM	INCH	PCS/BOX
R1611800A	25	55.1	575X320X607	22.6X23.9	1



FILTRATION



FLUID MONITORING



HOSE REELS



ACCESSORIES



AIR



ANTIFREEZE



DEF



BIODIESEL



DIESEL



FOOD



GASOLINE



GREASE



KEROSENE



OIL



WATER



WINDSCREEN

CHARTS

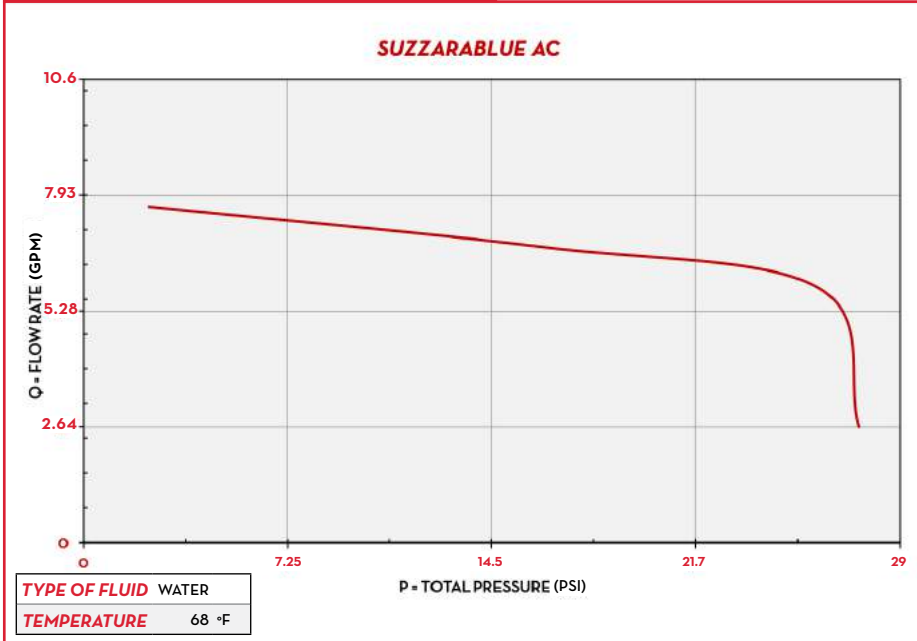

VARIOUS COMPONENTS

- BLUE BOX (R1611800A)
- SB PRO KIT (PAGE 20)
- MOUNTING PLATE (F20300000)
- PEDESTAL (OPTIONAL) (F1270800)

DETAILS



K24



AUTOMATIC NOZZLE



FOOT VALVE

DIMENSIONS

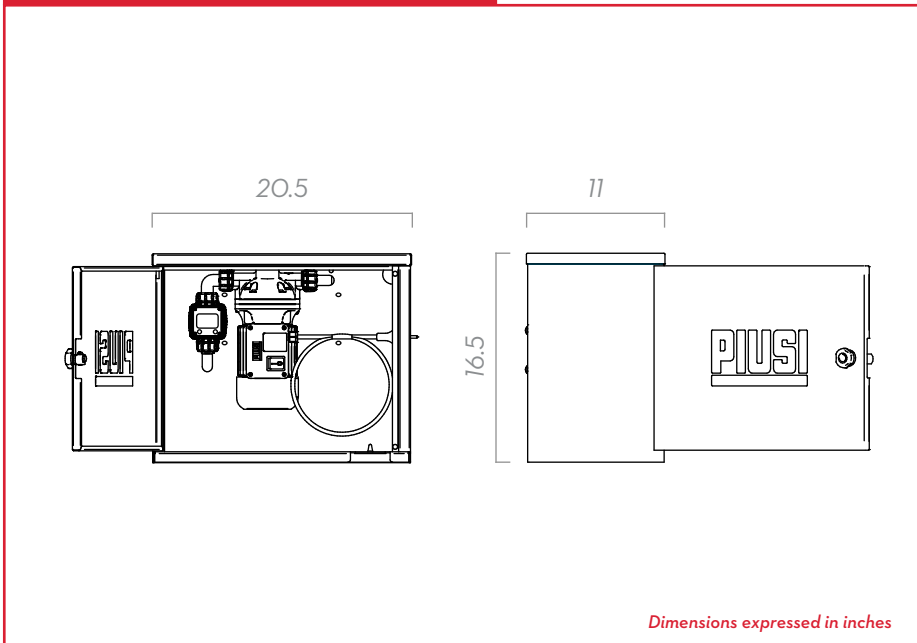

MATERIALS

- **PUMP:**
SUZZARBLUE PUMP AC PG. 28
- **METER:**
K24 METER PG. 46
- **NOZZLE:**
SUZZARBLUE A60 PG. 64

TECHNICAL DATA

PART #	DESCRIPTION	FLUIDS TYPE	FLOW RATE		VOLTAGE			METER	NOZZLE	HOSE LENGTH
			L/MIN	GPM	AC V/ HZ	DC VOLT	POWER WATT	AMP. MAX.	MOD.	
DEFPEDESTAL	DEF BLUE BOX PEDESTAL TANK KIT		34	9	120/60	400	1.95	K24	SUZZARBLUE NOZZLE A60	20 FT
R1611800A	KIT COMPLETE BOX FOR SUZZARBLUE BOX	-	-	-	-	-	-	-	-	-

DEF BLUE BOX PEDESTAL

STATIONARY